

APPLICATION NOTE

ABSTRACT

Different suppliers have introduced single-, dual-, and triple-gate devices, with many different names. This application note discusses the different call-outs for the various packages and provides the reader with a comparison of the drawings from different vendors.

AN10161

PicoGate Logic footprints

Author: Bob Marshall
Supersedes data of 2002 Aug 30

2002 Oct 29

PicoGate Logic footprints

AN10161

Most major Logic suppliers have added a new dimension to the standard logic package landscape with the introduction of the single-, dual- and triple-gate devices. These small packages are designated by many different names.

Philips Semiconductors calls their family PicoGate Logic™; Texas Instruments calls their family TinyLogic; Fairchild dubbed them Little Logic; ST calls theirs Single gate; ON Semiconductor calls their family MiniGate; Toshiba uses the moniker LMOS.

Trying to cross all of these families to a common package has become quite a chore. Suppliers have different names for their package outlines. There are 5-pin, 6-pin and 8-pin packages and each pin count is available with two different lead pitch options. The remainder of this paper will attempt to sort out the different call-outs for the various packages and provide the reader with a comparison of the drawings from different vendors.

The 5-pin packages

Depending on the vendor, the 5-pin 0.65 mm lead pitch package is known as MO-203, SC70, SC70-5, SC88A, SOT323, SOT353, SSOP-5-P-0.65A or USV. Figure 1 shows the general package outline and a table of the various dimensions. So despite all of the different names used, all of the packages are footprint compatible.

For the 5-pin 0.95 mm lead pitch package, much the same can be said. Depending on the vendor, the package is referenced as a SOT753, SC74A, SC59, SOT23, SOT23-5, MO178, TSOP5 and SMV. Figure 2 shows the general package outline for the 0.95 mm pitch package and a table of the various dimensions. Again, it can easily be shown that even though tolerances vary slightly, all of the parts are footprint compatible.

The 6-pin packages

The 6-pin package drawings have the same dimensions as the 5-pin package but have a 6th lead, so there are 3 pins on each side of the package. Philips, Fairchild and TI offer some single- and dual-gate devices in this package option. Fairchild differentiates the package by changing the package designator to P6X or M6X for the 0.65 and 0.95 mm pitch packages. However, Philips and TI use the same package designator as for the 5-pin package. ON Semiconductor and Toshiba do not offer a 6-pin device.

The 8-pin packages

Dual- and triple-gate logic functions are offered by Toshiba, Philips, TI and Fairchild and use an 8-pin package. As with the 5- and 6-pin packages, there are also two different lead pitches available. The 0.65 mm lead pitch package from Toshiba calls it an SSOP-8-P-0.65. Philips calls it a SOT505-2. TI calls it an SM8, and Fairchild doesn't offer the package. The smaller 8-pin package uses a 0.5 mm lead pitch and is known as the US8 or VSSOP8. Philips, Toshiba, Fairchild and TI offer this smaller package. Figures 3 and 4 are the package outline drawings.

While the package naming convention is not as straightforward as some of the more standard 14-, 16- and 20-pin package options, these smaller footprint packages are sourced by multiple vendors whose package footprints are all compatible with each other. The larger 0.95 mm lead pitch offers some space savings over the more conventional TSSOP package while it allows the use of low cost PC board etching techniques. Where the ultimate space savings is required, users have the option to shifting to a 0.65 or 0.5 mm pitch package.

PicoGate Logic footprints

AN10161

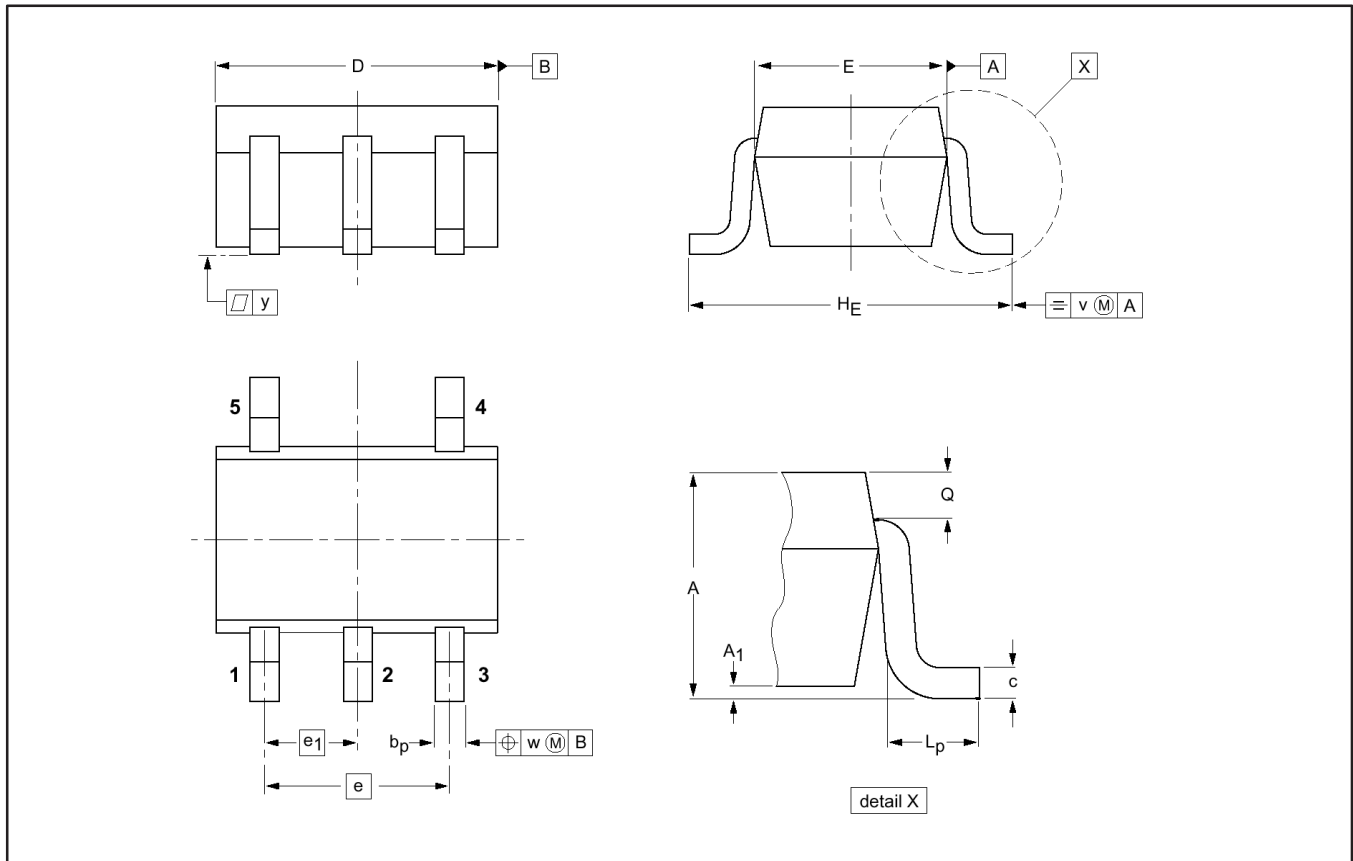

Figure 1. General package outline for a 5-pin 0.65 mm lead pitch package

All dimensions are in mm and are listed at the nominal value on the package drawing.

Table 1. 5-pin / 6-pin 0.65 mm lead pitch

Package	Dimension											Package designator
	A	A _{1 max}	b _p	c	D	E	e	e ₁	H _E	L _p	y	
SOT353 Philips	0.95	0.1	0.25	0.175	2.0	1.25	1.3	0.65	2.1	0.3	0.1	GW
SC70 T.I.	0.95	0.1	0.25	0.130	2.0	1.25	1.3	0.65	2.0	0.31	0.15	DCK
SC88A FCS	0.95	0.1	0.20	0.175	2.0	1.25	1.3	0.65	2.1	0.25	0.1	P5X/P6X
SOT323 ON	1.00	0.1	0.20	0.175	2.0	1.25	1.3	0.65	2.1	0.2	0.1	DFT
USV Toshiba	0.90	0.1	0.20	0.150	2.0	1.25	1.3	0.65	2.1	N/A	0.1	FU

PicoGate Logic footprints

AN10161

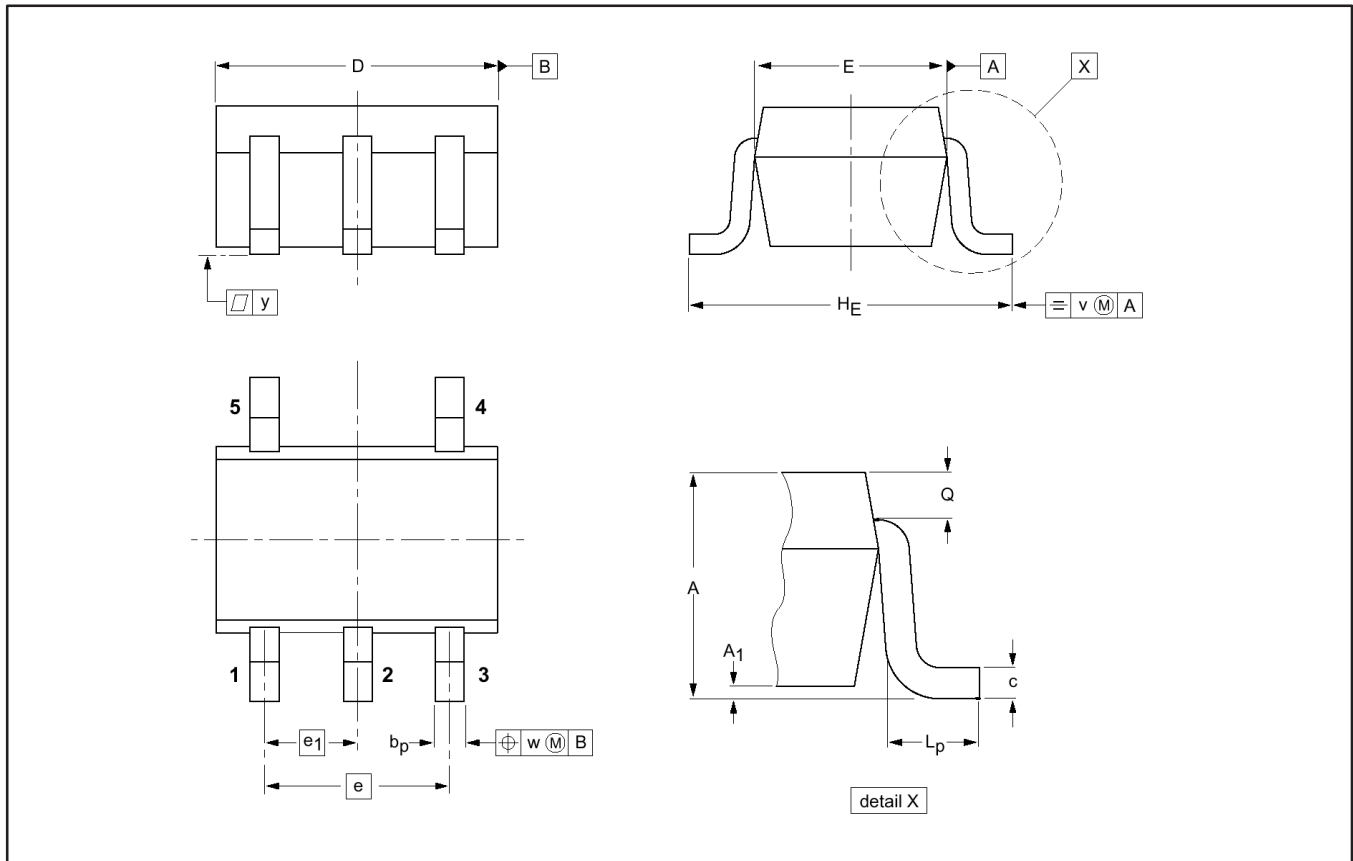

Figure 2. General package outline for a 5-pin 0.95 mm lead pitch package

All dimensions are in mm and are listed at the nominal value on the package drawing.

Table 2. 5-pin / 6-pin 0.95 mm lead pitch

Package	Dimension										Package designator
	A	A _{1 max}	b _p	c	D	E	e	H _E	L _p	y	
SOT753 Philips	1.000	0.10	0.325	0.180	2.9	1.5	0.95	2.75	0.40	0.10	GV
SOT23 T.I.	1.200	0.10	0.400	0.150	2.9	1.6	0.95	2.80	0.45	0.05	DBV
SOT23 FCS	1.175	0.10	0.400	0.140	2.9	1.6	0.95	2.80	0.45	0.10	M5X/M6X
SOT59-5 ON	1.000	0.10	0.375	0.175	3.0	1.5	0.95	2.75	0.40	0.05	DDT1
SMV Toshiba	1.100	0.10	0.400	0.160	2.9	1.6	0.95	2.80	N/A	0.10	F

PicoGate Logic footprints

AN10161

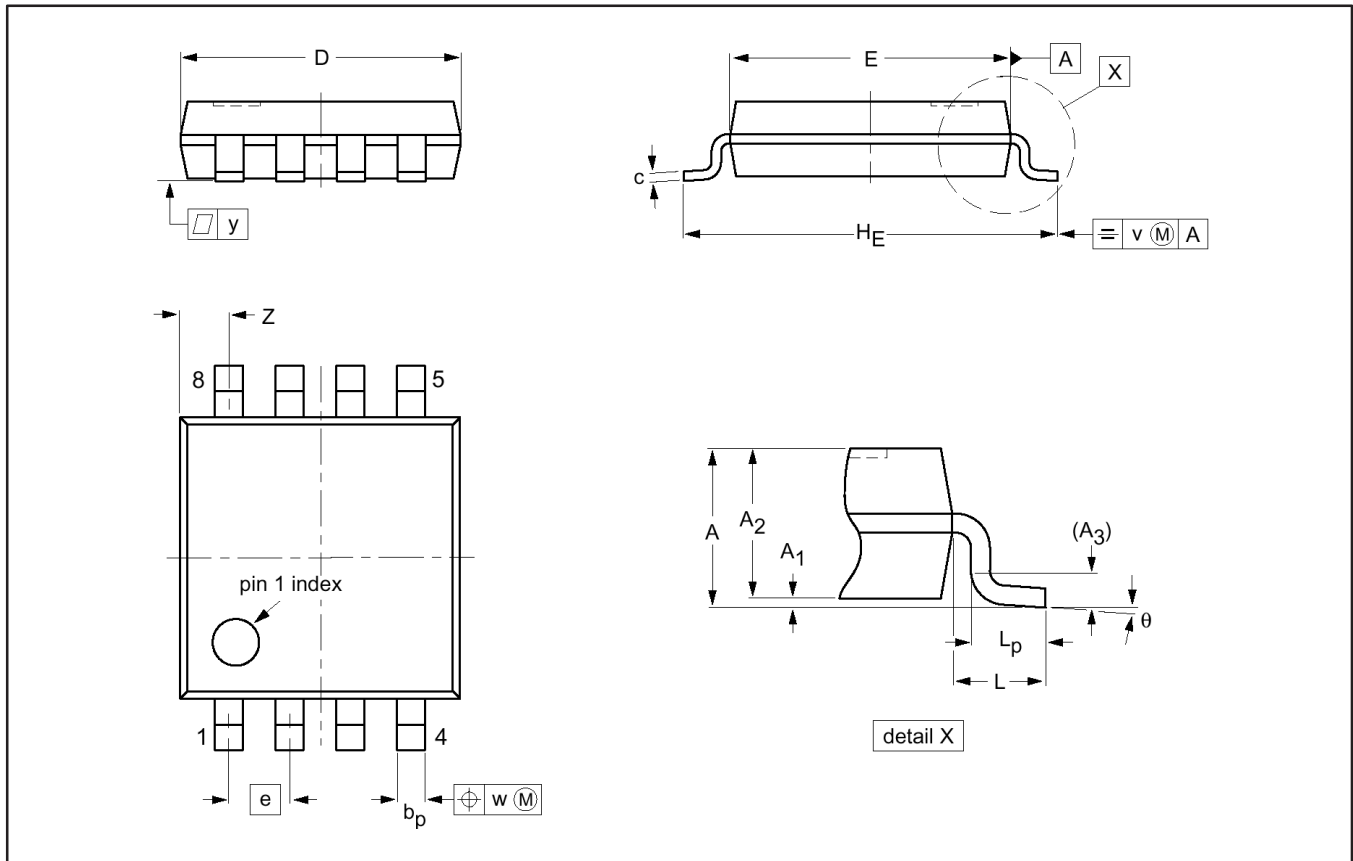

Figure 3. General package outline for an 8-pin 0.65 mm lead pitch package

All dimensions are in mm and are listed at the nominal value on the package drawing.

Table 3. 8-pin 0.65 mm lead pitch

Package	Dimension										Package designator
	A	A _{1 max}	b _p	c	D	E	e	H _E	L _p	y	
SOT505-2 Philips	1.100	0.15	0.280	0.130	3.00	3.00	0.65	4.00	0.40	0.10	DP
SM8 T.I.	1.300	0.10	0.225	0.150	2.95	2.80	0.65	4.00	0.40	0.10	DCT
SSOP8-P-0.65 Toshiba	1.100	0.50	0.200	0.150	2.90	2.90	0.65	4.00	N/A	0.10	FU

PicoGate Logic footprints

AN10161

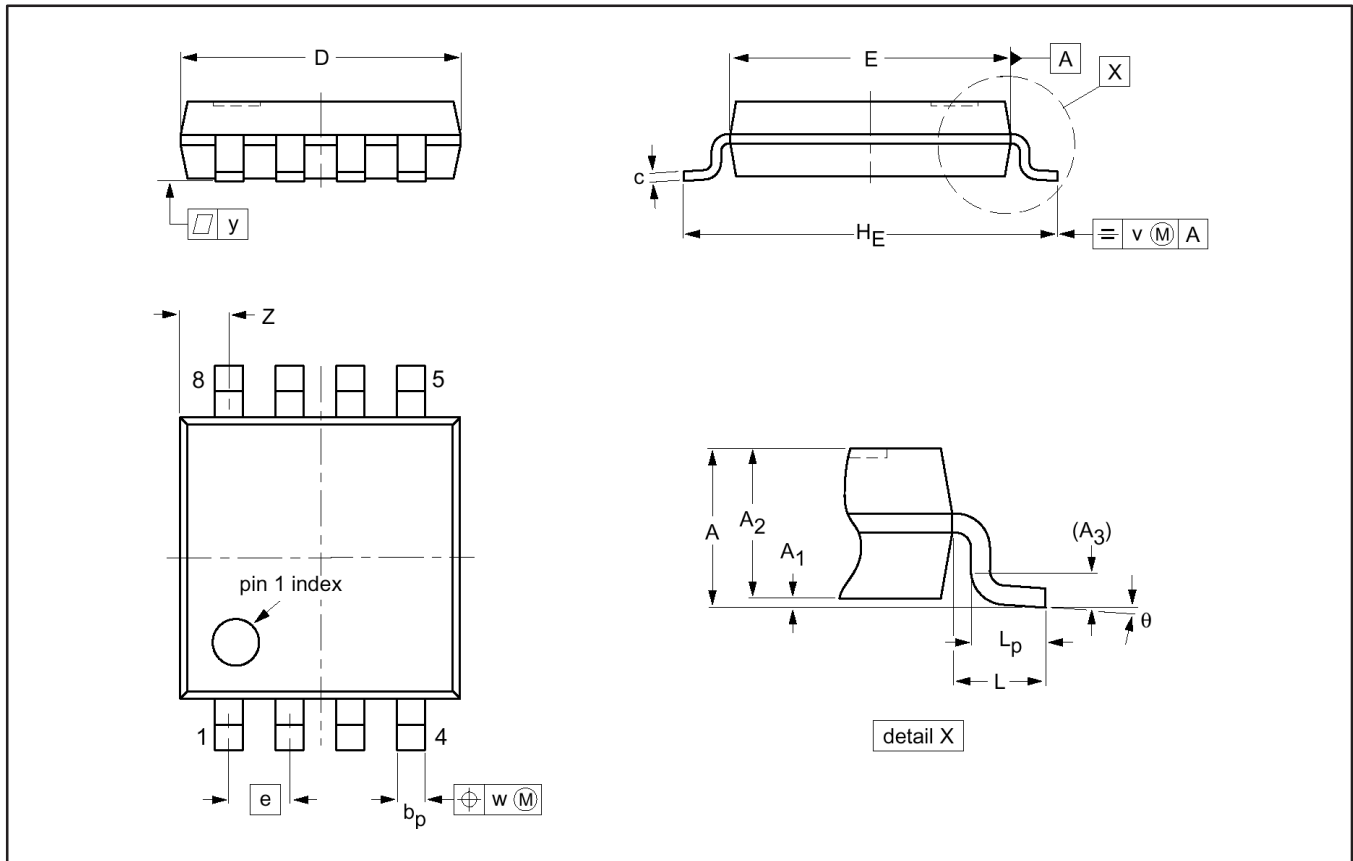

Figure 4. General package outline for an 8-pin 0.50 mm lead pitch package

All dimensions are in mm and are listed at the nominal value on the package drawing.

Table 4. 8-pin 0.50 mm lead pitch

Package	Dimension										Package designator
	A	A _{1 max}	b _p	c	D	E	e	H _E	L _p	y	
SOT765 Philips	1.000	0.15	0.220	0.140	2.00	2.20	0.50	3.10	0.275	0.10	DC
US8 T.I.	0.900	0.10	0.210	0.130	2.00	2.30	0.50	3.10	0.275	0.10	DCU
US8 Fairchild	0.900	0.10	0.220	0.130	2.00	2.30	0.50	3.10	0.275	0.10	K8X
VSSOP8 Toshiba	0.700	0.10	0.200	0.120	2.00	2.30	0.50	3.10	N/A	0.10	FK
US8 ON	0.900	0.10	0.210	0.120	2.00	2.30	0.50	3.10	0.275	0.10	US

PicoGate Logic footprints

AN10161

REVISION HISTORY

Rev	Date	Description
_2	20021029	Second version (9397 750 10634). Supersedes AN10161_1 of 30 August 2002 (9397 750 10267).
_1	20020830	Initial version (9397 750 10267).

Definitions

Short-form specification — The data in a short-form specification is extracted from a full data sheet with the same type number and title. For detailed information see the relevant data sheet or data handbook.

Limiting values definition — Limiting values given are in accordance with the Absolute Maximum Rating System (IEC 60134). Stress above one or more of the limiting values may cause permanent damage to the device. These are stress ratings only and operation of the device at these or at any other conditions above those given in the Characteristics sections of the specification is not implied. Exposure to limiting values for extended periods may affect device reliability.

Application information — Applications that are described herein for any of these products are for illustrative purposes only. Philips Semiconductors make no representation or warranty that such applications will be suitable for the specified use without further testing or modification.

Disclaimers

Life support — These products are not designed for use in life support appliances, devices, or systems where malfunction of these products can reasonably be expected to result in personal injury. Philips Semiconductors customers using or selling these products for use in such applications do so at their own risk and agree to fully indemnify Philips Semiconductors for any damages resulting from such application.

Right to make changes — Philips Semiconductors reserves the right to make changes in the products—including circuits, standard cells, and/or software—described or contained herein in order to improve design and/or performance. When the product is in full production (status 'Production'), relevant changes will be communicated via a Customer Product/Process Change Notification (CPCN). Philips Semiconductors assumes no responsibility or liability for the use of any of these products, conveys no license or title under any patent, copyright, or mask work right to these products, and makes no representations or warranties that these products are free from patent, copyright, or mask work right infringement, unless otherwise specified.

Contact information

For additional information please visit
<http://www.semiconductors.philips.com>. Fax: +31 40 27 24825

© Koninklijke Philips Electronics N.V. 2002
 All rights reserved. Printed in U.S.A.

Date of release: 10-02

For sales offices addresses send e-mail to:
sales.addresses@www.semiconductors.philips.com

Document order number:

9397 750 10634

Let's make things better.